

PAPILIO

LED YÜKSEK TAVAN ARMATÜRÜ
Led high ceiling luminaire



IP66



Işık Şiddeti Dağılım Eğrisi Light Distribution Curve

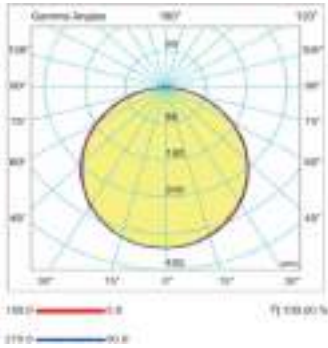

Teknik Çizim Technical Drawing

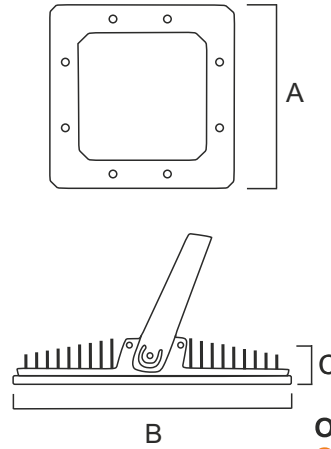

Uygulama Alanları Scope of application

- * Fabrika
Factory
- * Depo
Warehouse
- * Atölye
Workshop
- * Spor Salonu
Gymnasium

GENEL ÖZELLİKLER General Features

OPSİYONLAR Options

Gövde Body	Eloksal kaplı alüminyum ekstrüzyon Anodized extruded aluminium	Farklı RAL kodlarında elektrostatik toz boya uygulaması Electrostatic powder coating application in different RAL codes.
Led Led	>100.000 saat ömürlü ışık kaynağı >100.000 hour life light source	Acil aydınlatma uygulaması Emergency lighting application
Cam Glass	4 mm Temperli cam 4 mm Tempered Glass	DALI ve 1-10V dimleme uygulaması DALI and 1-10V dimming application
Verimlilik Efficiency	> 0,95 > 0,95	İsteğe uygun renk sıcaklığı uygulaması. (2700 k - 4000 k - 6500 k) Optional color temperature application. (2700 k - 4000 k - 6500 k)
Giriş Gerilimi Input Voltage	220 V - 240 V / 50-60 Hz 220 V - 240 V / 50-60 Hz	
Sürücü Driver	Yüksek verimli High efficiency	

TEKNİK BİLGİLER / Technical Specifications

Ürün Kodu Product Code	Güç Tüketimi Power (W)	Işık Akısı Lumen	Çalışma Sıcaklığı Operating Heat (C)	Ölçüler Dimensions (AxBxC) mm	Ağırlık Weight Kg	Kullanım Yüksekliği Using Height (m)
NS-444060	60	8520	-30...+70	335x335x90	3,100	H1:4 - H2:6
NS-444080	80	11360	-30...+70	335x335x90	3,100	H1:5 - H2:7
NS-444105	105	14910	-30...+70	335x335x90	3,100	H1:6 - H2:9